

- I** Bruciatori policombustibile kerosene/gasolio-gas
- GB** Dual fuel Kerosene/Gas oil-Gas burners
- F** Brûleurs mixtes kérosène et fioul-gaz
- D** Kerosin/Heizöl-Gas Mehrstoffbrenner
- E** Quemadores policombustible queroseno y gasóleo-gas

Funzionamento bistadio progressivo o modulante
Progressive two-stage or modulating operation
Fonctionnement à deux allures progressives ou modulant
Gleitend - zweistufiger oder modulierender Betrieb
Funcionamiento a 2 llamas progresivas o modulante

CODICE - CODE CÓDIGO	MODELLO - MODEL - MODELE MODELL - MODELO	TIPO - TYPE - TYP
20034832	GI/EMME 1400	680 T1
20034833	GI/EMME 1400	680 T1
20034834	GI/EMME 2000	681 T1
20034835	GI/EMME 2000	681 T1
20034247	GI/EMME 3000	682 T1
20034836	GI/EMME 3000	682 T1
20034248	GI/EMME 4500	683 T1
20034837	GI/EMME 4500	683 T1

680 T1
681 T1

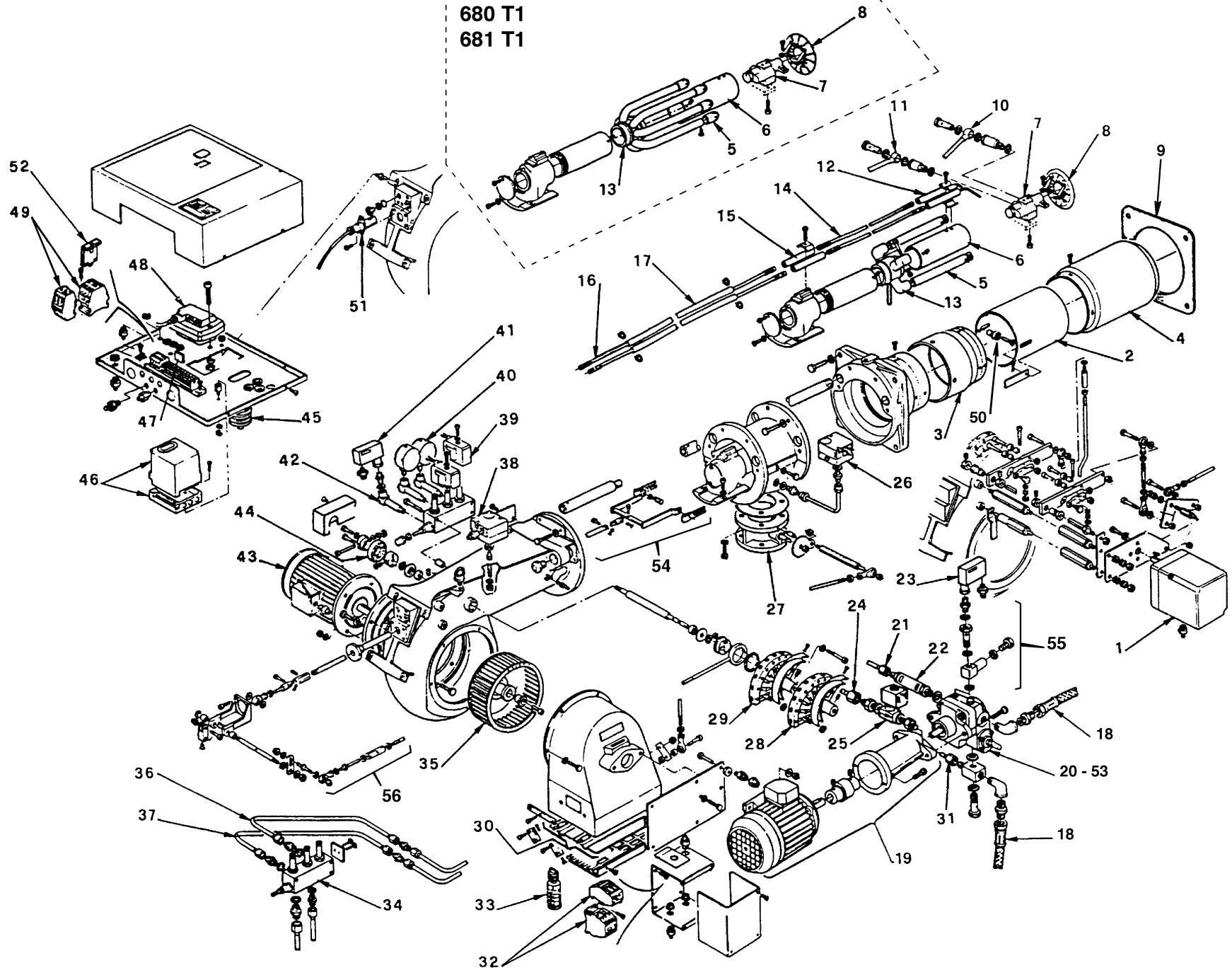

N.	COD.	20034832	20034833 *	20034834 *	20034835 *	20034247	20034836 *	20034248	20034837 *	DESCRIZIONE	DESCRIPTION	DESCRIPTION	BESCHREIBUNG	DENOMINACION	MATRICOLA BRUCIATORE BURNER SERIAL NUMBER MATRICULE BRULEUR BRENNER KENN-NUMMER MATRICULA QUEMADÓRES	**
1	3000871	•	•	•						SERVOMOTORE	SERVOMOTOR	SERVOMOTEUR	STELLMOTOR	SERVOMOTOR		B
2	3012243	•								CILINDRO	SLEEVE	CYLINDRE	ZYLINDER	CILINDRO		C
2	3012244		•							CILINDRO	SLEEVE	CYLINDRE	ZYLINDER	CILINDRO		C
2	3012215			•						CILINDRO	SLEEVE	CYLINDRE	ZYLINDER	CILINDRO		C
2	3012216				•					CILINDRO	SLEEVE	CYLINDRE	ZYLINDER	CILINDRO		C
2	3013441					•				CILINDRO	SLEEVE	CYLINDRE	ZYLINDER	MANGA		C
2	3013442						•			CILINDRO	SLEEVE	CYLINDRE	ZYLINDER	MANGA		C
2	3012271							•		CILINDRO	SLEEVE	CYLINDRE	ZYLINDER	MANGA		C
2	3012272								•	CILINDRO	SLEEVE	CYLINDRE	ZYLINDER	MANGA		C
3	3006193		•		•					PROLUNGA	EXTENSION	RALLONGE	VERLÄNGERUNG	PROLONGACIÓN		
3	3006245							•	•	PROLUNGA	EXTENSION	RALLONGE	VERLÄNGERUNG	PROLONGACIÓN		
4	3006233	•	•							IMBUTO FIAMMA	END CONE	ERBOUT GUEULAR	FLAMMENROHR	TUBO EXTREMO		B
4	3012245			•	•					IMBUTO FIAMMA	END CONE	ERBOUT GUEULARD	FLAMMENROHR	TUBO EXTREMO		B
4	3013440					•	•			IMBUTO FIAMMA	END CONE	ERBOUT GUEULARD	FLAMMENROHR	TUBO LLAMA		B
4	3006243							•	•	IMBUTO FIAMMA	END CONE	ERBOUT GUEULARD	FLAMMENROHR	TUBO LLAMA		B
5	3012247	•	•							DIFFUSORE	GAS NOZZLE	DIFFUSEUR	GAS VERTEILER	DIFUSOR		A
5	3012246			•	•					DIFFUSORE	GAS NOZZLE	DIFFUSEUR	GAS VERTEILER	DIFUSOR		A
5	3012273					•	•	•	•	TUBO	TUBE	TUYAUTERIE	DRUCKROHR	TUBO		
6	3012248	•	•	•	•	•	•	•	•	TUBO	TUBE	TUYAUTERIE	DRUCKROHR	TUBO		
7	3012249	•	•	•	•	•	•	•	•	PORTASPRUZZO	NOZZLE HOLDER	PULVERISATEUR	DÜSENSTOCK	PORTABOQUILLA		C
8	3012250	•	•	•	•					ELICA	DIFFUSER DISC	ACCROCHE FLAMME	STAUSCHEIBE	DISCO ESTABILIZADOR		A
8	3012275					•	•	•	•	ELICA	DIFFUSER DISC	ACCROCHE FLAMME	STAUSCHEIBE	DISCO ESTABILIZADOR		A
9	3006180	•	•	•	•					SCHERMO	FLANGE GASKET	ECRAN THERMIQUE	FLANSCHDICHTUNG	JUNTA AISLANTE		A
9	3006244					•	•	•	•	SCHERMO	FLANGE GASKET	ECRAN THERMIQUE	FLANSCHDICHTUNG	JUNTA AISLANTE		A
10	3012251	•	•							TUBO	TUBE	TUYAUTERIE	DRUCKROHR	TUBO		
10	3012252		•	•						TUBO	TUBE	TUYAUTERIE	DRUCKROHR	TUBO		
10	3012276					•	•			TUBO	TUBE	TUYAUTERIE	DRUCKROHR	TUBO		
10	3012277						•	•		TUBO	TUBE	TUYAUTERIE	DRUCKROHR	TUBO		
11	3012253	•	•							TUBO	TUBE	TUYAUTERIE	DRUCKROHR	TUBO		
11	3012254		•	•						TUBO	TUBE	TUYAUTERIE	DRUCKROHR	TUBO		
11	3012278					•	•			TUBO	TUBE	TUYAUTERIE	DRUCKROHR	TUBO		
11	3012279						•	•		TUBO	TUBE	TUYAUTERIE	DRUCKROHR	TUBO		
12	3012255	•	•	•	•	•	•	•	•	ELETTRODO	ELECTRODE	ELECTRODE PORCELAINE	ELEKTRODE	ELECTRODO		A

N.	COD.	20034832	20034833 *	20034834	20034835 *	20034247	20034836 *	20034248	20034837 *	DESCRIZIONE	DESCRIPTION	DESCRIPTION	BESCHREIBUNG	DENOMINACION	MATRICOLA BRUCIATORE BURNER SERIAL NUMBER MATRICULE BRULEUR BRENNER KENN-NUMMER MATRICULA QUEMADÓRES		* *
13	3012256	•	•							DISTRIBUTORE	GAS NOZZLE RING	MELANGEUR	VERTEILER	DISTRIBUIDOR			
13	3012257		•	•						DISTRIBUTORE	GAS NOZZLE RING	MELANGEUR	VERTEILER	DISTRIBUIDOR			
13	3012280				•	•	•	•		DISTRIBUTORE	GAS NOZZLE RING	MELANGEUR	VERTEILER	DISTRIBUDOR			A
14	3012267	•	•							COLLEGAMENTO	H.T. LEAD	CABLE H.T.	ZÜNDKABEL	CABLES ELECTRODOS			A
14	3012268		•	•						COLLEGAMENTO	H.T. LEAD	CABLE H.T.	ZÜNDKABEL	CABLES ELECTRODOS			A
14	3012281				•	•				COLLEGAMENTO	H.T. LEAD	CABLE H.T.	ZÜNDKABEL	CABLE ELECTRODO			
14	3012282					•	•			COLLEGAMENTO	H.T. LEAD	CABLE H.T.	ZÜNDKABEL	CABLE ELECTRODO			
15	3012258	•	•	•	•	•	•	•	•	ISOLATORE	INSULATOR	PORCELAINE D'ELEC- TRODE	ISOLATOR	AISLATOR			
16	3012162	•	•	•	•					COLLEGAMENTO	H.T. LEAD	CABLE H.T.	ZÜNDKABEL	CABLES ELECTRODOS			A
16	3012163				•	•	•	•		COLLEGAMENTO	H.T. LEAD	CABLE H.T.	ZÜNDKABEL	CABLE ELECTRODO			
17	3003101	•	•	•	•	•	•	•	•	TUBETTO	TUBE	TUYAU	RÖHRCHEN	TUBO			
18	20034085	•	•	•	•	•	•	•	•	TUBO FLESSIBILE	HOSE	FLEXIBLE	SCHLAUCH	TUBO FLEXIBILE			A
19	20050918	•	•	•	•					MOTORE	MOTOR	MOTEUR	MOTOR	MOTOR			C
19	20050919				•	•	•	•		MOTORE	MOTOR	MOTEUR	MOTOR	MOTOR			C
20	3006157	•	•							POMPA	PUMP	POMPE	PUMPE	BOMBA			C
20	3006158		•	•						POMPA	PUMP	POMPE	PUMPE	BOMBA			C
20	3006236				•	•				POMPA	PUMP	POMPE	PUMPE	BOMBA			C
20	3006410						•	•		POMPA	PUMP	POMPE	PUMPE	BOMBA			
21	3012260	•	•	•	•					TUBO	TUBE	TUYAUTERIE	DRUCKROHR	TUBO			
21	3012284				•	•	•	•		TUBO	TUBE	TUYAUTERIE	DRUCKROHR	TUBO			
22	3003178	•	•	•	•	•	•	•	•	FILTRO	FILTER	FILTRE	FILTER	FILTRO			A
23	20037208	•	•	•	•	•	•	•	•	PRESSOSTATO OLIO	OIL PRESSURE SWITCH	PRESSOSTAT FIOUL	ÖLDRUCKWÄCHTER	PRESÓST. DE ACEITE			B
24	3012261	•	•	•	•					TUBO	TUBE	TUYAUTERIE	DRUCKROHR	TUBO			
24	3012285				•	•	•	•		TUBO	TUBE	TUYAUTERIE	DRUCKROHR	TUBO			
25	3012165				•	•	•	•		VALVOLA	SOLENOID VALVE	SOUPAPE ELECTRIQUE	ELEKTROVENTIL	VÁLVULA			B
26	3003660	•	•	•	•	•				PRESSOTATO GAS	GAS PRESSURE SWITCH	PRESSOSTAT GAZ	GASDRUCKWÄCHTER	PRESÓSTATO GAS			B
26	3012286						•	•		PRESSOTATO GAS	GAS PRESSURE SWITCH	PRESSOSTAT GAZ	GASDRUCKWÄCHTER	PRESÓSTATO GAS			B
27	3006096	•	•							REGOLATORE GAS	BUTTERFLY VALVE	CLAPET GAZ	GASDROSSELKLAPPE	REGULADOR GAS			C
27	3012262		•	•						REGOLATORE GAS	BUTTERFLY VALVE	CLAPET GAZ	GASDROSSELKLAPPE	REGULADOR GAS			C
27	3006590				•	•	•	•		REGOLATORE GAS	BUTTERFLY VALVE	CLAPET GAZ	GASDROSSELKLAPPE	REGULADOR GAS			C
28	3006093	•	•	•	•	•	•	•	•	CAMMA COMPLETA	CAM ASSEMBLY	CAME COMPLETE	VERBUNDREGLER	EXCÉNTRICO COMPLETO			C
29	3012263	•	•	•	•	•	•	•	•	CAMMA COMPLETA	CAM ASSEMBLY	CAME COMPLETE	VERBUNDREGLER	EXCÉNTRICO COMPLETO			C
30	3012264	•	•	•	•					GRUPPO SERRANDA	AIR DAMPER ASSEMBLY	GROUPE VOLET AIR	LUFTKLAPPE	CONJU. REGISTRO AIRE			

N.	COD.	20034832	20034833 *	20034834	20034835 *	20034247	20034836 *	20034248	20034837 *	DESCRIZIONE	DESCRIPTION	DESCRIPTION	BESCHREIBUNG	DENOMINACION	MATRICOLA BRUCIATORE BURNER SERIAL NUMBER MATRICULE BRULEUR BRENNER KENN-NUMMER MATRICULA QUEMADORES	* *
30	3012370									GRUPPO SERRANDA	AIR DAMPER ASSEMBLY	GROUPE VOLET AIR	LUFTKLAPPE	GRUP. TOMA PRES. AIRE		
31	3012457	•	•	•	•	•	•	•	•	TUBO	TUBE	TUYAUTERIE	DRUCKROHR	TUBO		
32	3012818	•	•	•	•	•	•	•	•	AVVIATORE	STARTER	DEMARREUR	ANLASSER	APAREJADOR		C
33	3003640	•	•	•	•	•	•	•	•	COMMUTATORE	SELECTOR SWITCH	COMMUTEUR	WAHLSCHALTER	CONMUTADOR		
34	3006227	•	•	•	•					MODULATORE	MODULATOR	MODULATEUR	MODULATOR	MODULADOR		B
34	3006227					•	•			MODULATORE	MODULATOR	MODULATEUR	MODULATOR	MODULADOR	≤ 02132xxxx	B
34	20029107					•	•			MODULATORE	MODULATOR	MODULATEUR	MODULATOR	MODULADOR	≥ 02142xxxx	B
34	20029107						•	•		MODULATORE	MODULATOR	MODULATEUR	MODULATOR	MODULADOR		B
35	3005508	•	•							GIRANTE	FAN	TURBINE	GEBLÄSERAD	TURBINA		C
35	3012070			•	•					GIRANTE	FAN	TURBINE	GEBLÄSERAD	TURBINA		C
35	3012287					•	•			GIRANTE	FAN	TURBINE	GEBLÄSERAD	TURBINA		C
35	3006240						•	•		GIRANTE	FAN	TURBINE	GEBLÄSERAD	TURBINA		C
36	3012265	•	•	•	•					TUBO	TUBE	TUYAUTERIE	DRUCKROHR	TUBO		
36	3012288					•	•	•	•	TUBO	TUBE	TUYAUTERIE	DRUCKROHR	TUBO		
37	3012266	•	•	•	•					TUBO	TUBE	TUYAUTERIE	DRUCKROHR	TUBO		
37	3012289					•	•	•	•	TUBO	TUBE	TUYAUTERIE	DRUCKROHR	TUBO		
38	3006593	•	•	•	•	•	•	•	•	PRESSOSTATO ARIA	AIR PRESSURE SWITCH	PRESSOSTAT AIR	LUFTDRUCKWÄCHTER	PRESÓSTATO AIRE		A
39	3003001	•	•	•	•	•	•	•	•	BOBINA	COIL	BOBINE E.V.	MV-SPULE	BOBINA		B
40	3006140	•	•	•	•	•	•	•	•	MANOMETRO	PRESSURE GAUGE	MANOMETRE	MANOMETER	GALGA DE PRESIÓN		
41	20037209	•	•	•	•	•	•	•	•	PRESSOSTATO OLIO	OIL PRESSURE SWITCH	PRESSOSTAT FIOUL	ÖLDRUCKWÄCHTER	PRESÓST. DE ACEITE		B
42	3006540	•	•	•	•	•	•	•	•	VALVOLA	NEEDLE VALVE	ROBINET POINTEAU	NADELVENTIL	VÁLVULA		B
43	3008408	•	•							MOTORE	MOTOR	MOTEUR	MOTOR	MOTOR		C
43	3013352			•	•					MOTORE	MOTOR	MOTEUR	MOTOR	MOTOR		C
43	3012274					•	•			MOTORE	MOTOR	MOTEUR	MOTOR	MOTOR		C
43	3013588						•	•		MOTORE	MOTOR	MOTEUR	MOTOR	MOTOR		C
44	3003186	•	•	•	•	•	•	•	•	CUSCINETTO	BEARING	ROULEMENT	LAGER	COJINETE		
45	3003149	•	•	•	•	•	•	•	•	CUFFIA	COWLING	PROTECTION CAOUT- CHOUC	SCHUTZ	CAPUZÓN		
46	3006090	•	•	•	•	•	•	•	•	APPARECCHIATURA	CONTROL BOX	BOITE DE CONTROLE	STEUERGERÄT	CAJA DE CONTROL		B
47	3012155	•	•	•	•	•	•	•	•	FILTRO ANTIDISTURBO	DEGLITCHER	FILTRE	ENTSTÖRER	FILTRO ANTI INTERF.		
48	3012164	•	•	•	•	•	•	•	•	TRASFORMATORE	TRANSFORMER	TRANSFORMATEUR	ZÜNDTRANSFORMATOR	TRANSFORMADOR		B
49	3012361	•	•	•	•	•				AVVIATORE	STARTER	DEMARREUR	ANLASSER	APAREJADOR		C

N.	COD.									DESCRIZIONE	DESCRIPTION	DESCRIPTION	BESCHREIBUNG	DENOMINACION	MATRICOLA BRUCIATORE BURNER SERIAL NUMBER MATRICULE BRULEUR BRENNER KENN-NUMMER MATRICULA QUEMADORES	* *
		20034832	20034833 *	20034834	20034835 *	20034247	20034836 *	20034248	20034837 *							
50	3014191					•	•	•	•	GRUPPO MOVIMENTAZIONE TESTA DI COMBUSTIONE	COMBUSTION HEAD MOVEMENT ASSEMBLY	GROUPE MOUVEMENT TÊTE	KOPF-BEWEGUNGSSYSTEM	GRUPO MOVIMIENTO CABEZAL		C
51	3003396	•	•	•	•	•	•	•	•	FOTOCPELLULA U.V.	U.V. DETECTOR	PHOTOCPELLULA U.V.	U.V. PHOTOZELLE	FOTOCPELLULA U.V.		C
52	3012362					•	•			BLOC. CONTATTI AUSILIARI	AUXILIARY CONTACT BLOCK	BLOC CONTAC. AUXILIARES	THERMISCHES RELAIS	BLOQ. CONT. AUXILIAR		
53	3000804					•	•	•	•	ORGANO DI TENUTA	PUMP SEAL	ORGANE D'ETANCHEITE	WELLENDICHTUNG	CONJ. ESTANQUIDAD		
54	3014188					•	•	•	•	GRUPPO MOVIMENTAZIONE TESTA DI COMBUSTIONE	COMBUSTION HEAD MOVEMENT ASSEMBLY	GROUPE MOUVEMENT TÊTE	KOPF-BEWEGUNGSSYSTEM	GRUPO MOVIMIENTO CABEZAL		C
55	3014189					•	•	•	•	RACCORDI PRESSOSTATO OLIO	OIL PRESSURE SWITCH CONNECTOR	MAMELON PRESSOSTAT FIOUL	ÖLDRUCKWÄCHTER-NIPPEL	RACORD PRESÓSTATO ÓLEO		C
56	3014190					•	•	•	•	GRUPPO LEVE	LEVER ASSEMBLY	GROUPE LEVIER	HEBEL	GRUPO LEVAS		C

*

Versione Testa Lunga - Long Combustion Head Version - Version Tête Longue - Langer Brennkopf Ausführung

**

RICAMBI CONSIGLIATI - ADVISED PARTS - RECHANGE CONSEIL - EMPFOHLENE ERSATZTEILE

A = Ricambi per dotazione minima - Spare parts for minimum fittings - Pièces détachées pour équipement minimum - Ersatzteile für minimale Ausstattung

A+B = Ricambi per dotazione base di sicurezza - Spare parts for basic safety fittings - Pièces détachées pour équipement standard de sécurité - Ersatzteile für Sicherheitsgrundausrüstung

A+B+C = Ricambi per dotazione estesa di sicurezza - Spare parts for extended safety fittings - Pièces détachées pour équipement complet de sécurité - Ersatzteile für erweiterte Sicherheitsausstattung

RIELLO

RIELLO S.p.A.
I-37045 Legnago (VR)
Tel.: +39.0442.630111
[http:// www.rielloburners.com](http://www.rielloburners.com)